



SPONSORED BY THE POWER OF REDARC



FROM \$15,990



BEST CAMPER
UNDER \$25,000
BEST VALUE
FOR MONEY CAMPER



WINNER
BEST VALUE FOR MONEY
★ ★ ★
MARLIN ULTIMATE REAR FOLD



MARLIN EXPLORER

5+ Persons

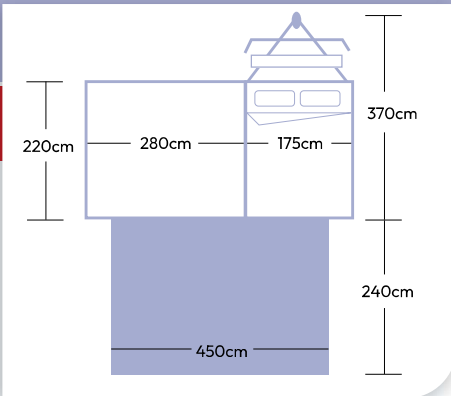

KEY FEATURES

- ★ Australian Owned - Australian Made
- ★ Towable by the Smallest of Cars
500kg Tare • 50kg Ball Weight
- ★ 1 Person Set Up in just 2 Minutes
- ★ Insulated Roof: Cool in Summer • Warm in Winter

MARLINCAMPERS.COM.AU

- FINANCE AVAILABLE
- 6 MONTH LAY BY WITH 10% DEPOSIT

INCLUSIONS

**TENT TOP
ON YOUR TRAILER**
Fits High Side 7 x 4 Trailer:
\$6499



**UPGRADE
YOUR TRAILER**

LIGHT OFF ROAD

Suitable for dirt roads, national parks,
light beach driving.

50 x 50 RHS chassis, 40mm Square Axle,
Eye to Eye Off Road Suspension, Brand
New 235/75/15 All Terrain Tyres,
100 x 50 Drawbar, Sealed Tailgate,
2nd Stabiliser Leg. Rear Recovery Mount.

EXTREME OFF ROAD

Upgrade to Rebound Eye to Eye Suspension,
45mm Square Axle, Ark XO Off Road Hitch,
Front Corner Bash Plates.



MARLIN021 - COPP THIS GRAPHICS - 0431/456 186

PRODUCT	PRICE \$	STANDARD \$15,990	DELUXE \$17,990	ULTIMATE \$22,990
TRAILER				
<input type="checkbox"/> Light Off Road Trailer Upgrade	2000			N/A
<input type="checkbox"/> Extreme Off Road Trailer Upgrade	2900			•
<input type="checkbox"/> Side Hinged Access	450	•	•	•
<input type="checkbox"/> Tool Box with Extended Drawbar	550	•	•	•
<input type="checkbox"/> Pole Carrier	200	•	•	•
<input type="checkbox"/> Vertical Bracket for Spare Wheel	100	•	•	•
<input type="checkbox"/> Spare Wheel Cover	150		•	•
<input type="checkbox"/> Bike Rack Receiver	195			
<input type="checkbox"/> Jerry Can/Gas Bottle Holders	95	1 of Each	1 of Each	2 of Each
<input type="checkbox"/> Brakes Mechanical/ Electrical	From 750 / 900			
<input type="checkbox"/> Tie Down Rails	150			•
<input type="checkbox"/> Boat Rack	650			
<input type="checkbox"/> Off Road Hitch	450			•
<input type="checkbox"/> Stoneguard	695			•
<input type="checkbox"/> Galvanised Trailer	1590			
<input type="checkbox"/> Marine Carpet Lined Trailer Floor	200		•	•
WATER				
<input type="checkbox"/> 60 Litre Water Tank	750	•	•	•
<input type="checkbox"/> External Hand Pump	95			
<input type="checkbox"/> Hot Water System with Shower	599		•	•
<input type="checkbox"/> External Water Inlet	95			
<input type="checkbox"/> External Mains Tap	145			
KITCHEN				
<input type="checkbox"/> Tailgate Kitchen	INC	•		
<input type="checkbox"/> Deluxe Tailgate Kitchen	+450		•	•
<input type="checkbox"/> Slide Out Conversion	+600			
<input type="checkbox"/> Fridge Slide	+500			
<input type="checkbox"/> Pantry/Storage Drawer	750			
<input type="checkbox"/> 40 Litre Drawer Fridge	1390			
<input type="checkbox"/> 60 Litre Premium Fridge/Freezer	1699			
<input type="checkbox"/> 80 Litre Fridge/Freezer	1599			
<input type="checkbox"/> Hot Water to Kitchen	150			
POWER				
<input type="checkbox"/> Lithium Power Pack		•		
<input type="checkbox"/> Lithium Power Pack + 700w Inverter	+600		•	
<input type="checkbox"/> Lithium Power Pack + 1200w Inverter	+1200			•
<input type="checkbox"/> 200AH Lithium Power Pack with Inverter	+2400			
<input type="checkbox"/> Solar Panel	From 499			•
<input type="checkbox"/> Internal/External Power Outlets	150 Each		2	2
<input type="checkbox"/> Car/Solar Charging	150 Each			
ADDITIONAL ROOMS				
<input type="checkbox"/> Explorer Front Room Kit	1500			
<input type="checkbox"/> Explorer Rear Room Kit	1500			
TOTAL				

DISCLAIMER: Prices and availability are subject to change. Marlin Campers will inform you of any price fluctuation where possible.

TOTAL \$

Telephone: **0409 887 927**

info@marlincampers.com.au • Unit 1, 24 Pile St Somersby NSW 2250

MARLINCAMPERS.COM.AU